



# GT SHELL



## TECHNICAL DATA SHEETS



[www.guardtech.com](http://www.guardtech.com)



0330 113 0303



[sales@guardtech.com](mailto:sales@guardtech.com)



Guardtech House, Unit 1A Homefield Road, Haverhill, Suffolk, CB9 8QP



# DIRECTORY



Introduction **pg 4**



GT Shell Max **pg 6**



GT Shell Pro **pg 8**



GT Shell Plus **pg 10**



GT Shell Lite **pg 12**



GT Shell Fire **pg 14**



Comparisons **pg 16**



# GT SHELL CLEANROOM WALLS



Guardtech offer a range of cleanroom wall solutions to best suit the needs of your application. Whether it's budget, lead time or performance that matters most, Guardtech provide a comprehensive choice of wall options to ensure your process requirements are achieved.

Whether it's a more economical PIR option all the way up to a sophisticated fully flush integrated interlocking panel system, the Guardtech Group's Directors, Design Engineers and Installation team have worked together to carefully select four industry-leading ceiling options for your consideration.

Read on to discover the benefits and compromises of the different choices we have, then use this guide to make the most informed cleanroom wall choice possible.

Let Guardtech take your operation to the next level.



## SHELL MAX

GT Shell Max is Guardtech's elite-level cleanroom wall solution – a high-spec, customisable, modular, flush controlled environment system featuring a de-mountable joint with an aluminium extrusion to all sides.



## SHELL PRO

GT Shell Pro's insulated panel system features a unique castellated and symmetrical de-ended tongue-and-groove joint which achieves high thermal and structural performance..



## SHELL PLUS

GT Shell Plus is Guardtech's lower mid-level cleanroom wall solutions – a high-performance insulated wall panel that maintains hygiene-safe requirements when exposed to corrosive cleaning agents.



## SHELL LITE

GT Shell Lite is Guardtech's entry-level cleanroom wall solution – a 50mm PIR insulated powder-coated modular composite panel that can be used for a wide range of cleanroom applications.



## SHELL FIRE

GT Shell Fire is Guardtech's fire-rated wall solution – a high-quality cleanroom grade panel which provides a tested fire resistance to match the performance required for internal firewalls.





# GT SHELL MAX



GT Shell Max is Guardtech's elite-level cleanroom wall solution – a high-spec, customisable, modular, flush controlled environment system featuring a demountable joint with an aluminium extrusion to all sides.

GT Shell Max is a customisable, modular fully flush cleanroom system that features a demountable joint with an aluminium extrusion to all sides.

It is suitable for specialist cleanroom applications that demand specific core performance, aiding compliance to EU GMP Annex 1, ISO 14644-1 and US FS209E.

This intelligent fully flush modular system

for specialist cleanroom applications comes with a choice of three core options: QuadCore, Mineral Fibre Core and Aluminium Honeycomb.

Attention to utility integration is a key part of GT Shell Max, with specially designed raceways and conduits that are embedded within the panel system to eliminate any surface mounted wiring or pipe-work and containment, also facilitating flush integrated sockets.

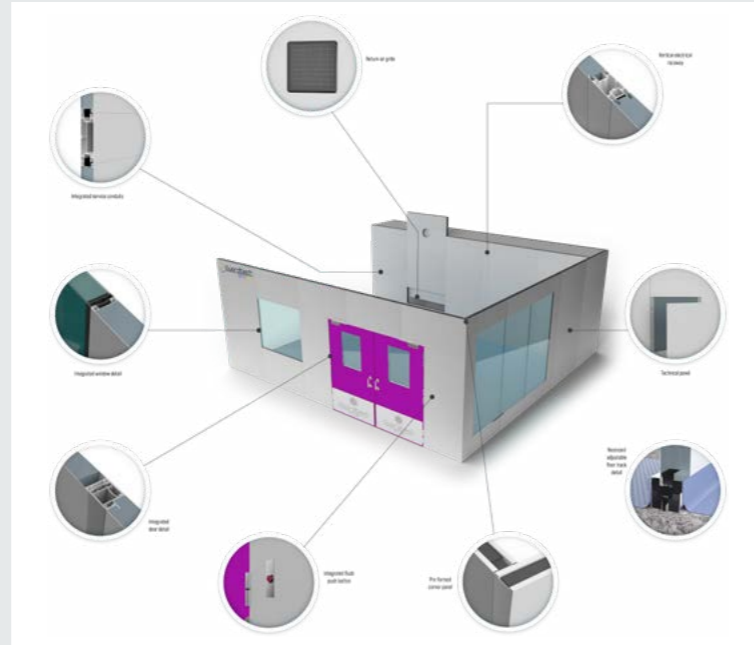

## TECHNICAL FEATURES

### DIMENSIONS, WEIGHT & PERFORMANCE

OVERALL THICKNESS (MM)	60, 80	
STANDARD WIDTHS* (MM)	1200	
LENGTH (MM)	300-5700mm	
WEIGHT (0.63 / 0.63 STEEL)	14kg/m <sup>2</sup>	

\*Variable widths available as non standard, in 10mm increments. Minimum width 150mm.

### PRODUCT TOLERANCES

LENGTH (MM)	+1.5	-1.5
WIDTH (MM)	+1.5	-1.5
THICKNESS (MM)	+2.0	-2.0
FLATNESS (PER METRE) (MM)	+1.0	-1.0
END SQUARENESS (MM)	+2.0	-2.0



## TECHNICAL DRAWINGS



## ALUMINIUM HONEYCOMB PANEL

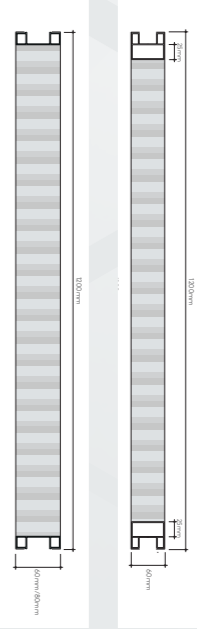

GT Shell Max Aluminium Honeycomb panels achieve airtightness of less than 0.003m<sup>3</sup>/hr/m<sup>2</sup> at 50Pa in accordance with EN 14509.

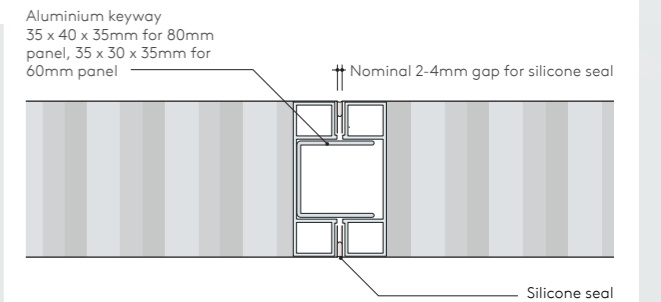
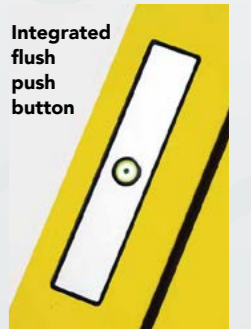

### BENEFITS

- cGMP compliant solution
- 60mm panel joint features an optional service cavity for incorporation of services
- Integrated envelope solution – doors, windows, corners, floor tracks and other components
- Choice of cores – QuadCore, Mineral Fibre core or Aluminium Honeycomb
- Wide range of CLEANsafe coating systems
- Ultra-airtight system
- Available in both 60mm and 80mm thicknesses providing superior load bearing capacity and stability
- Flexibility – variable widths to suit layout

### COMPROMISES

- The most expensive option in the GT Shell range
- Potentially longer lead times than other options in the range
- Heavier panels than both those used in GT Shell Pro and Plus systems

### APPLICATIONS

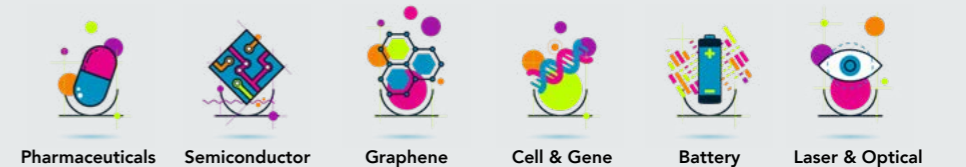

GT Shell Max suits the most demanding of applications, typically where particulate needs to be controlled to extremely tight tolerances. This often includes cleanrooms with an ISO5 or 6 classification, as well as those required to comply with cGMP conditions outlined in EU GMP Annex 1, ISO 14644-1 and US FS209E.



# GT SHELL PRO



GT Shell Pro's insulated panel system features a unique castellated and symmetrical de-ended tongue-and-groove joint which achieves high thermal and structural performance.

GT Shell Pro is an insulated de-ended panel system designed for all internal controlled environments applications including new build and refurbishment projects.

The range offers flexible, high performance, engineered cleanroom solutions that deliver both cost and operational benefits, minimising risk and maximising return on investment.

This revolutionary hybrid

de-ended system offers a high-performance solution at a more competitive cost base than traditional methods. A factory-engineered based detail to allow it to sit on a recessed floor track to give a fully flush floor to wall detail suitable for both vinyl and resin.

Insertion of an interface profile in the panel joint to allow integration of fully flush windows, doors and service panels.



## TECHNICAL FEATURES

### DIMENSIONS, WEIGHT & THERMAL PERFORMANCE

CORE THICKNESS (MM)	50	60	80	100	125	150	175	200	220
U-Value (W/m <sup>2</sup> K)	0.38	0.31	0.23	0.18	0.15	0.12	0.10	0.09	0.08
R-Value (m <sup>2</sup> K/W)	2.63	3.23	4.35	5.560	6.67	8.33	10.00	11.11	12.50
Weight (kg/m <sup>2</sup> )	10.1	10.5	11.2	12.0	12.9	13.9	14.8	15.8	16.5

These values are in accordance with BS EN 14509, using Finite Element Analysis, and take into account any thermal bridging through the longitudinal joint.

The U-Values have been calculated using an aged thermal conductivity value of 0.018W/mK.

### ACOUSTIC (SOUND REDUCTION INDEX)

FREQUENCY (HZ)	63	125	250	500	1000	2000	4000	8000
SRI (dB)	20	15	17	23	18	25	40	46



## TECHNICAL DRAWINGS

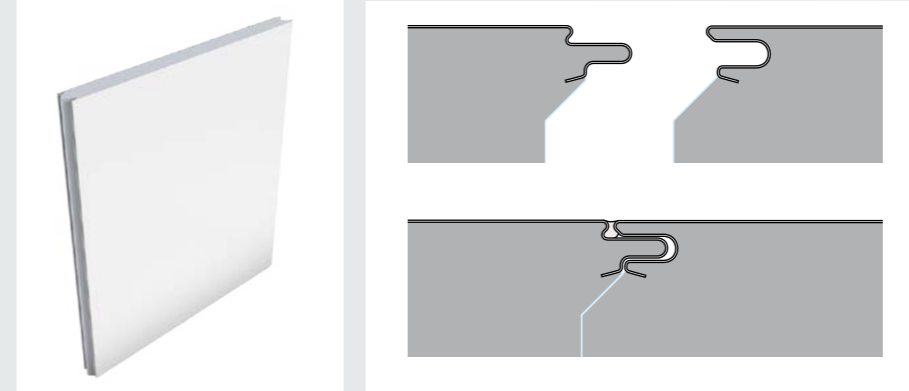

Panel joints achieve an air tightness of 0.02m<sup>3</sup>/h.m at 50Pa in accordance with BS EN 14509 with joint sealed using gun grade sealant.

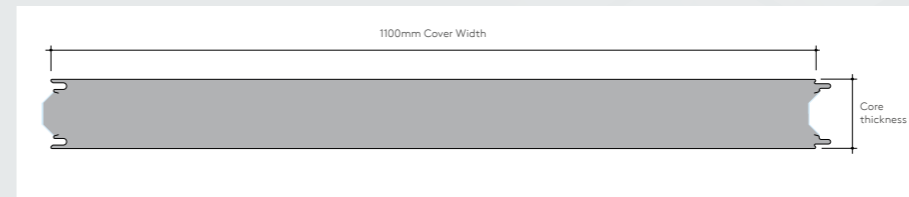

### AVAILABLE LENGTHS

Standard Lengths 2.0 – 11.9 m  
Longer Lengths\* 11.9 – 19 m  
Shorter Lengths\* <2.0 m

\* Non-standard lengths. Additional costs and transport restrictions may apply for non-standard lengths.

**Below:** Insertion of an interface profile in the panel joint to allow integration of fully flush windows, doors and service panels.

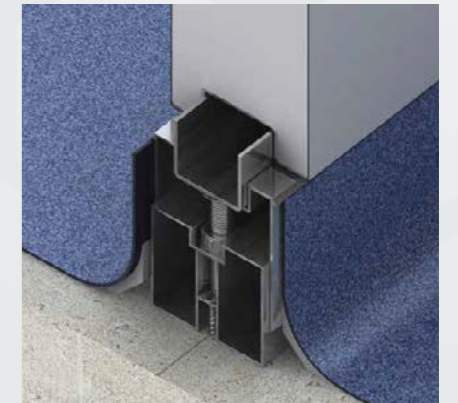

## PRODUCT FEATURES

- THICKNESS:** 60mm or 80mm
- PANEL LENGTH:** Up to 6.3m
- PANEL CORE:** QuadCore® (ks1100 ut-f is approved to Fm 4882)
- PANEL COATINGS:** Cleansafe 25, 55, 120, Anti-static 25 & stainless 304 & 316l

## BENEFITS

- Unique hybrid system
- Bespoke design flexibility combined with all the advantages of an insulated panel and its beneficial economies of scale
- Consistent high quality, factory engineered system
- Simple and fast construction
- Interlocking tongue-and-groove joint system.
- Integrated solution – doors, windows, corners, floor tracks, air return panels and other components
- Longer panel lengths - cleanroom heights over six metres
- Ultra-airtight system.
- Wide range of CLEANsafe coating systems

## COMPROMISES

- The whole integrated system is not fully flush system and therefore not entirely ledge-free like GT Shell Max
- Not as cost-effective as GT Plus or GT Lite
- Potentially longer lead times than GT Plus or Lite

## APPLICATIONS



GT Shell Pro cleanroom wall solution suits a wide variety of applications in a diverse range of sectors. Whilst it may not boast the fully flush appeal of GT Shell Max, this unique tongue-and-groove system does offer many of the same benefits needed by applications with more stringent requirements.



# GT SHELL PLUS



GT Shell Plus is Guardtech's lower mid-level cleanroom wall solutions – a high-performance insulated wall panel that maintains hygiene-safe requirements when exposed to corrosive cleaning agents.

GT Shell Plus is a high-performance insulated wall panel for controlled environments.

These washable surfaces provide a sealed monolithic structure for maintaining hygiene-safe requirements when exposed to corrosive cleaning agents.

The tight fitting-panel joints offer superior airtightness, preventing thermal bridging and condensation.

These enhanced panels are ideal for temperature ranges of between -40 °C to ambient temperatures, and feature an innovative joint system designed to withstand high pressure washing and regular cleaning; preventing water ingress and minimising potential bacteria growth.



## TECHNICAL FEATURES

DIMENSIONS, WEIGHT AND THERMAL PERFORMANCE			
T-CORE THICKNESS (MM)	100	200	300
U-value (W/m <sup>2</sup> K)	0.18	0.12	0.09
R-value (m <sup>2</sup> K/W)	5.56	8.33	11.11
Weight (kg/m <sup>2</sup> ) Steel 0.5 / 0.5 mm	13.36	15.45	17.54

U-values are calculated in accordance with EN14509:2013 (Section A.10.3). R-values in Imperial units (ft<sup>2</sup>·°F·hr/BTU) available upon request.

### FIRE PERFORMANCE

This hybrid insulation core system has passed all the requirements of:

- TS EN 13501-1:2007 + A1:2009: B-s1, d0

- TS EN 13501-2 achieved E120 & E120 (100 mm panel) – vertically applied wall application
- FM 4880 / FM 4881 / FM 4882 – Class 1

PRODUCT FEATURES	
Core Type:	QuadCore
Metal Type: Steel / Stainless Steel	Steel / Stainless Steel
Colours and Coatings:	A large selection of external colours and coating options are available with a wide variety of finishes including metallic, matte and solid. Please consult a rep to get the best coating and finish recommendation for your project depending on its geographic location, building use / function and warranty requirements
Cover Width:	1100mm
Acoustic Insulation:	Approx. 25 dB across all panel thicknesses
Environmental Rating:	Zero Ozone Depleting Potential (ODP), Low Global Warming Potential (GWP) Free from CFC, HCFC & HFC, free from halogenated flame retardants
Seals:	Site applied



## TECHNICAL DRAWINGS



These hygienic and fibre-free insulated wall panel systems are available in three profiles, suitable for internal and external walls and ceilings, including 'box within a box' applications.



**AVAILABLE LENGTHS**  
Standard Lengths 2.0 – 11.9 m  
Longer Lengths\* 11.9 – 19 m  
Shorter Lengths\* <2.0 m

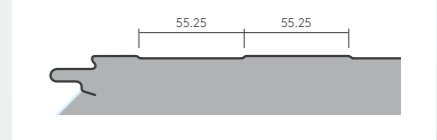

\* Non-standard lengths. Additional costs and transport restrictions may apply for non-standard lengths.

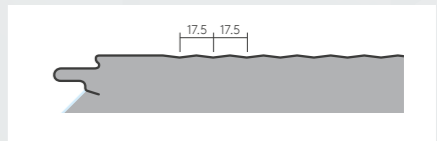
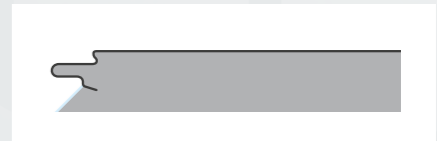

### BENEFITS

- Low air leakage
- Wide range of accessories available
- Incorporates a panel joint that achieves excellent thermal performance and can accommodate vapour and hygiene safe seals
- Suitable for temperatures from -40 °C to ambient
- Closed-cell insulation eliminates moisture ingress and performance failure
- Large range of profiles, coatings and insulation core thicknesses to meet project specific demands
- Available in lengths up to 15 m (subject to transport limitations)
- More competitive price point than GT Max and Pro

### PRODUCT FEATURES

**PRECISE THERMAL CONTROL**

**SUPERIOR AIRTIGHTNESS**

**SUPERIOR COATINGS AND LINERS**

**LOW U-VALUE**

**FASTER BUILD SPEED**

### COMPROMISES

- Doesn't feature the intelligent interlocking panel arrangements that GT Max and GT Pro include – this includes the hidden service conduits and other key benefits
- Inferior overall performance compared to GT Max and GT Pro solutions

### APPLICATIONS



GT Shell Plus is a versatile cleanroom wall solution suitable for a significant number of different industries using controlled environments as part of their process. GT Shell Plus offers a comparatively strong alternative to GT Max and Pro without the same intelligent interlocking panel system.



# GT SHELL LITE

GT Shell Lite is Guardtech's entry-level cleanroom wall solution – a 50mm PIR insulated powder-coated modular composite panel that can be used for a wide range of cleanroom applications.



GT Shell Lite is the Guardtech Group's entry-level cleanroom wall solution – a 50mm PIR insulated powder-coated modular composite panel.

GT Shell Lite is a far less sophisticated wall panel option compared to the rest of the GT Shell range, but it offers a strong level of reliability and performance at a highly competitive price point, making it an attractive choice for a wide range of applications in the broad spectrum of industries the Guardtech Group serves.



## TECHNICAL FEATURES

### GT SHELL LITE PANEL PROPERTIES

Stock Material	According to EN 14509 A.10
Core	PIR
Fire Classification	(EN 13501-1)B-S1,d0
Colour	White RAL 9003 – Polyester 25µm
U-Value	0.45 W/m <sup>2</sup> K
Sheet Thickness	0.5mm Internal & External
Profile	Smooth
Panel Weight	19KG



A typical side view of a GT Shell Lite PIR-insulated wall panel. These versatile panels sandwich profile panels offer decent thermal insulation properties.



# RAPID CLEANROOMS



**Isopod**  
rapid cleanrooms



GT Shell Lite panels are utilised in the Guardtech Group's range of standard Isopod Rapid Cleanrooms. GT Shell Lite marries high performance and reliability at a competitive price point that allows Guardtech to provide a quick-assembly, 'off-the-shelf', flat-pack cleanroom solution that delivers a level of quality that far outstrips any competitor in the cleanroom pod space.



### BENEFITS

- By far the most competitive wall panel solution from a price-point perspective
- Accessible procurement option with short lead times
- Decent thermal insulation
- Good panel for expansion and future relocation purposes

### COMPROMISES

- Significantly heavier than any other panel in the GT Shell range
- Doesn't feature the intelligent interlocking service channel system that superior GT Shell options have
- No optional extras in terms of additional hygienic protection and panel coating upgrades as per the rest of the GT Shell range

### APPLICATIONS



GT Shell Lite is commonly utilised in projects with less demanding regulations and standards – such laboratories and non-classified controlled environments – but this reliable solution is still capable of providing a high enough level of performance for most cleanroom applications.



# GT SHELL FIRE



GT Shell Fire is Guardtech's fire-rated wall solution – a high-quality cleanroom grade panel which provides a tested fire resistance to match the performance required for internal firewalls.

GT Shell Fire offers a total internal cleanroom wall solution that is ideally suited for non-load bearing internal partition walls and ceilings.

These high-quality panels provides a tested fire resistance to match the performance required for internal firewalls, protected zones, ceilings and compartmentation walls.

GT Shell Fire panels are manufactured with a stone wool core that provides built-in passive fire protection, structural strength, robustness and low environmental impact.

GT Shell Fire panels are available in a wide range of finishes including a foodsafe coating, providing a smooth, anti-static internal surface.



## TECHNICAL FEATURES

### FIRE RESISTANCE PERFORMANCE

PANEL THICKNESS (MM)	FIRE RESISTANCE (MINS)		MAXIMUM UNSUPPORTED LENGTH (M)	
	Insulation	Integrity	LPS 1208	BS476 Pt22
150	240	240	7.5**	11.5**
170	240	240	7.5**	12.0**
200	240	240	7.5	12.0
240	240	240	7.5	12.0

\*\*Panel joint stitched on both sides at 300mm centres using 3.8mm diameter x 16mm long stainless steel rivets.

Fire resistance is generally a requirement of Building Regulations but can also be used when compartmentation within buildings is required, it is measured in terms of: i) Integrity - the ability of a system to prevent the penetration of hot gases and flames.

ii) Insulation - the ability of the system to reduce the temperature rise on the unexposed side of the fire and therefore prevent fire spread through radiated heat.

### TOLERANCES

LENGTH	±10mm
WIDTH	±1mm
THICKNESS	±2mm
CORNERS (Leg length)	±3mm
FLATNESS	1.5mm (from the theoretical flat plane over a distance of 700mm)
JOINT GAP	±2mm

### WEIGHTS

CORE THICKNESS	WEIGHT: LITE (kg/m2)
50	-
75	-
100	-
125	-
150	29.9
170	32.9
200	35.9
240	40.7



## TECHNICAL DRAWINGS

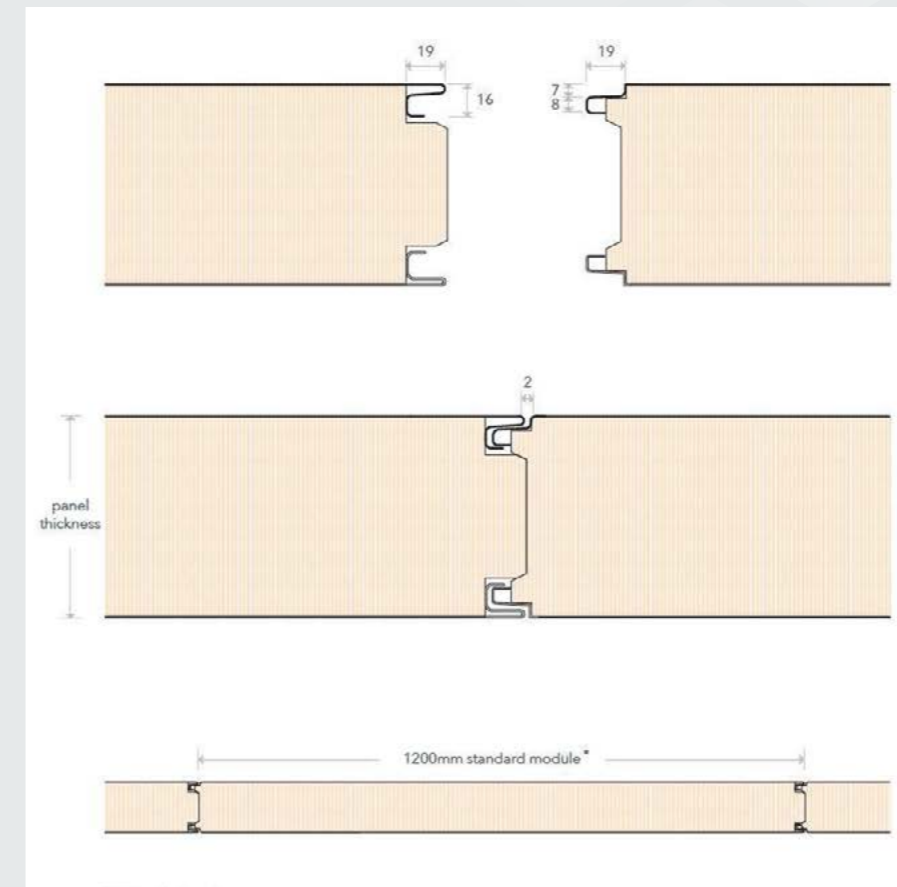

### VERTICAL JOINT DETAIL

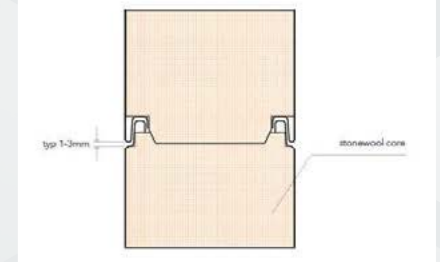

### TYPICAL WALL/FLOOR JUNCTION

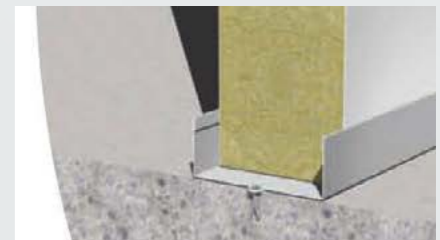
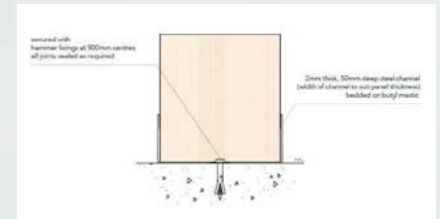

### BENEFITS

- Tested fire resistance to match the performance required for internal firewalls
- Stone wool core that provides built-in passive fire protection, structural strength, robustness and low environmental impact
- Wide range of finishes including a foodsafe coating, providing a smooth, anti-static internal surface

### COMPROMISES

- Doesn't feature the intelligent interlocking panel arrangements that GT Max and GT Pro include – this includes the hidden service conduits and other key benefits
- Inferior overall performance compared to GT Max and GT Pro solutions
- More expensive wall solution than GT Lite and Plus

### APPLICATIONS



GT Shell Fire is a fire-rated cleanroom wall solution that can be adopted throughout a number of different sectors where there is a concerted requirement for fire safety, either from a compliance perspective or as part of a business' wider policy and expectations.





# QUICK-LOOK COMPARISON GUIDE

## FEATURES



FEATURES	MAX	PRO	PLUS	LITE
Designed for cGMP compliance	<input checked="" type="checkbox"/>	<input type="checkbox"/>	<input type="checkbox"/>	<input type="checkbox"/>
Fully flush (entire system)	<input checked="" type="checkbox"/>	<input type="checkbox"/>	<input type="checkbox"/>	<input type="checkbox"/>
Semi flush	<input type="checkbox"/>	<input checked="" type="checkbox"/>	<input checked="" type="checkbox"/>	<input checked="" type="checkbox"/>
Superior quality panel system	<input checked="" type="checkbox"/>	<input checked="" type="checkbox"/>	<input type="checkbox"/>	<input type="checkbox"/>
QuadCore insulation option	<input checked="" type="checkbox"/>	<input checked="" type="checkbox"/>	<input checked="" type="checkbox"/>	<input type="checkbox"/>
Interlocking panel system	<input checked="" type="checkbox"/>	<input checked="" type="checkbox"/>	<input type="checkbox"/>	<input type="checkbox"/>
Aluminium honeycomb insulation option	<input checked="" type="checkbox"/>	<input type="checkbox"/>	<input type="checkbox"/>	<input type="checkbox"/>
Mineral Fibre Core insulation option	<input checked="" type="checkbox"/>	<input type="checkbox"/>	<input type="checkbox"/>	<input type="checkbox"/>
PIR insulation	<input type="checkbox"/>	<input type="checkbox"/>	<input type="checkbox"/>	<input checked="" type="checkbox"/>
CleanSafe coating option	<input checked="" type="checkbox"/>	<input checked="" type="checkbox"/>	<input checked="" type="checkbox"/>	<input type="checkbox"/>
Comparitively lightweight	<input type="checkbox"/>	<input checked="" type="checkbox"/>	<input checked="" type="checkbox"/>	<input type="checkbox"/>





Guardtech  

---

group

[www.guardtech.com](http://www.guardtech.com)

Guardtech House,  
Unit 1A Homefield Road,  
Haverhill, Suffolk,  
CB9 8QP