



GT FLOW



TECHNICAL DATA SHEETS



www.guardtech.com



0330 113 0303



sales@guardtech.com



Guardtech House, Unit 1A Homefield Road, Haverhill, Suffolk, CB9 8QP



DIRECTORY



Introduction **pg 4**



GT Flow Max **pg 6**



GT Flow Pro **pg 8**



GT Flow Plus **pg 10**

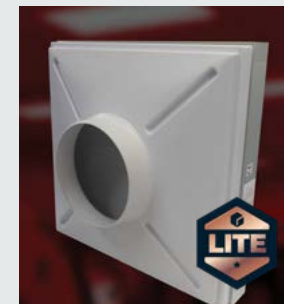

GT Flow Lite **pg 12**



Comparisons **pg 14**



GT FLOW FAN FILTER UNITS



Guardtech offer a range of filtration solutions to best suit the needs of your application. Whether it's budget, lead time or performance that matters most, Guardtech provide a comprehensive choice of fan filter units (FFUs) to ensure your process requirements are achieved.

Whether it's a more economical energy-saving FFU with reduced power consumption you prefer, or a fan filter unit with the option to perform a Roomside Filter Change, the Guardtech Group's Directors, Design Engineers and Installation team have worked together to carefully select four industry-leading filtration options for your consideration.

Read on to discover the benefits and compromises of the different choices we have, then use this guide to make the most informed FFU choice possible.

Let Guardtech take your operation to the next level.



FLOW MAX

GT Flow Max is a new generation energy-saving Fan Filter Unit with superior performance and reduced power consumption by more than 50% – featuring Roomside Filter Change as standard and a gel seal.



FLOW PRO

GT Flow Pro is a robust, reliable Fan Filter Unit (FFU) with an efficient EC motor and H14 HEPA filters, which helps to deliver on low energy consumption. This FFU implements a gel seal.



FLOW PLUS

GT Flow Plus is Guardtech's mid-level Fan Filter Unit (FFU) – featuring an efficient AC motor which helps to deliver on low energy consumption, this FFU implements a gel seal.



FLOW LITE

GT Flow Lite is Guardtech's entry-level filtration solution – it's the perfect solution for creating cleanrooms with vertical laminar flow. These are typically installed in false ceilings with proper aluminium profiles.



FLOW FIRE

This product range does not currently include a Fire Rated solution. Please consult a Guardtech rep for more information on your fire safety options.

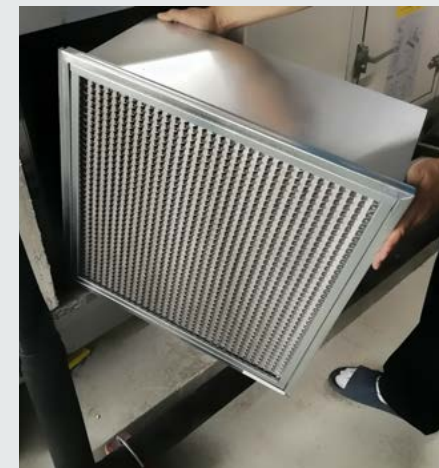



GT FLOW MAX



GT Flow Max is a new generation energy-saving Fan Filter Unit with superior performance and reduced power consumption by more than 50% – featuring Roomside Filter Change as standard and a gel seal.

GT Flow Max is a new generation energy saving FFU with superior performance.

Utilising world-class motors and HEPA filters, the GT Flow Max has reduced power consumption by more than 50%.

Combining energy-efficient electronically commutative (EC) motors, soundtec acoustical insulation, aluminium construction and fully addressable controls systems, the GT Flow Max FFU has the technology to exceed all expectations.



TECHNICAL FEATURES

EC MOTORS

Electronically commutative motors for reduced energy consumption

AERODYNAMIC IMPELLER

For optimized airflow

LPD

LPD (low pressure drop) HEPA filter for increased energy savings

AIRFLO PLC

For intelligent FFU control and monitoring

SOUNDTEC INSULATION

For advanced sound attenuation

ALUMINIUM CASING

With anodised finish

LOW ENERGY CONSUMPTION

LOW OPERATING SOUND



TECHNICAL DRAWINGS

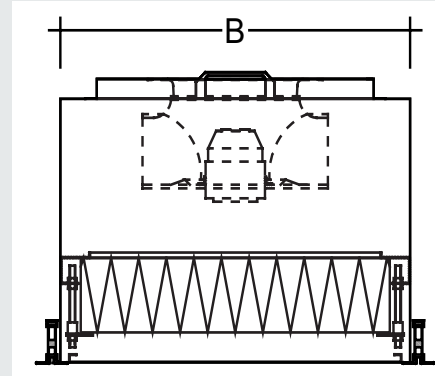
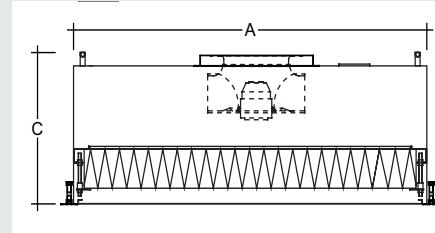

Fan Filter Unit Data	
Size	1170mm x 1170mm
Motor	EC
Voltage	1 - 200...277V 50/60 Hz
Watts	500w
Impeller	Backward curved
TSP	310 Pa
Controls	Airflo PLC
Filter size	1080mm x 1080mm
Filter type	H14 LPD Gel seal
Air volume at 0.45m/s	1786 m ³ /h
Vibration	1.4 mm/s

Parameters	
Area	26m ²
Ceiling Height	2.9m
Sound meter height	1.2m FFL
Velocity	0.45m/s
Air volume	8930 m ³ /h
Air change rate	120 hour

Results	
FFU running power	75w
Sound power	49.4 dB(A)
NR	46
Filter face uniformity	0.01m/s

OPTIONS

- ULPA filters – 99.9995% efficient at 0.12 micron particle size
- Stainless steel housing for corrosive environments
- RFC (Room Filter Change) Gel filter and motor replacement from the roomside
- Air inlet spigot connection
- AMC (Airborne Molecular Contamination) filter options
- G4 Pre-filter



Filter size	Air volume	TSP	Max power	Weight	A	B	C
480 x 480	328	360	320	29	570	570	450
780 x 480	547	240	490	37	870	570	450
1080 x 480	765	370	490	44	1170	570	450
1080 x 780	1276	290	500	55	1170	870	480
1080 x 1080	1786	310	500	67	1170	1170	480

BENEFITS

- Reduced power consumption thanks to high-performance EC motor makes this the range's most-efficient option
- Constructed to allow for roomside filter change
- Gel seal
- Acoustic insulation offers most superior noise level performance in GT Flow range

COMPROMISES

- Higher price point
- No slimline model available (if required, speak to a member of the Guardtech team and an alternative will be provided)

APPLICATIONS



Pharmaceuticals

Semiconductor

Graphene

Cell & Gene

Battery

Laser & Optical

GT Flow Max suits the most demanding of applications, typically where particulate needs to be controlled to extremely tight tolerances. This often includes cleanrooms with an ISO5 or 6 classification, as well as those required to comply with cGMP conditions outlined in EU GMP Annex 1, ISO 14644-1 and US FS209E.





GT FLOW PRO



GT Flow Pro is a robust, reliable Fan Filter Unit (FFU) with an efficient EC motor and H14 HEPA filters, which helps to deliver on low energy consumption. This FFU implements a gel seal.

GT Flow Pro is a robust, reliable Fan Filter Unit with an efficient EC motor and H14 HEPA filters.

The GT Flow Pro model gives users the flexibility of Roomside Filter Change and implements a gel seal.

Providing outstanding performance, efficiency and value in its class, GT Flow Pro is available with both individual and group control systems and a wide range of further options. Please ask a Guardtech rep for more information.



TECHNICAL FEATURES

EFFICIENT EC MOTORS

BACKWARD CURVED FAN

H14 HEPA FILTER

99.995% efficient at 0.3 micron particle size

TRIAC CONTROLLER OPTIONS

AIRFLO PLC CONTROLS

Options for intelligent FFU control and monitoring

GALVANISED CASING

LOW ENERGY CONSUMPTION

LOW OPERATING SOUND

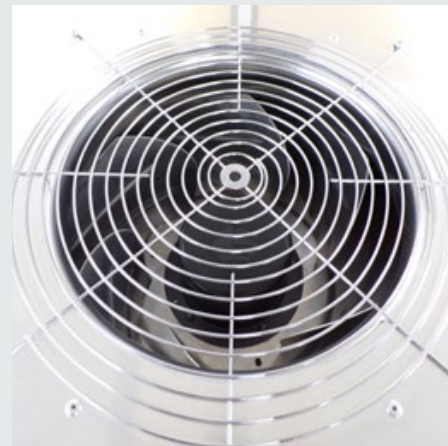

TECHNICAL DRAWING

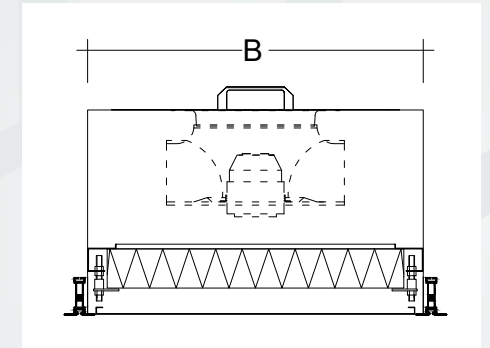
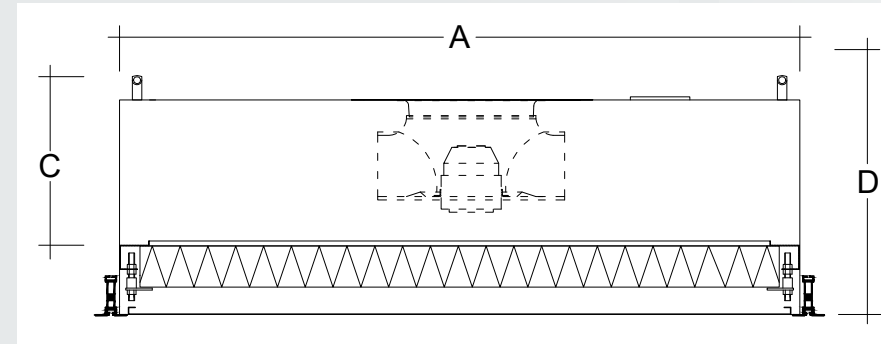

DIMENSIONS

A	B	C	D
570	570	355	490
870	570	355	440
1170	570	355	440
1170	870	355	440
1170	1170	355	440

OPTIONS

- ULPA filters – 99.9995% efficient at 0.12 micron particle size
- AMC (Airborne Molecular Contamination) filter options
- Air inlet spigot connection
- Plug and play wiring options
- G4 Pre-filter

- The GT Flow Pro FFU allows for Roomside Filter Change.
- This FFU also features a gel seal.
- Topside Filter Change also available.



BENEFITS

- Efficient EC motor
- Low energy consumption
- Gel seal
- Constructed to allow for roomside filter change
- Superior noise reduction performance compared to GT Flow Lite and Plus

COMPROMISES

- Higher price point
- Inferior noise reduction performance compared to GT Flow Max

APPLICATIONS

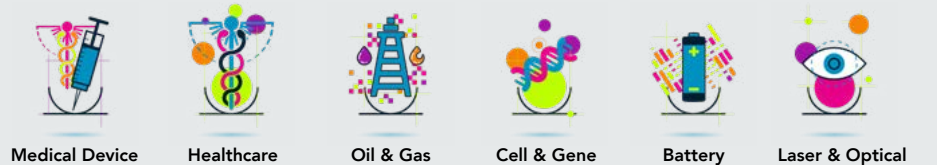

GT Flow Pro FFUs cover a wide range of applications with a varying degree of air change rate requirements. This version of the dependable all-rounder does include the option for roomside change – giving it far more flexibility than the GT Flow Plus incarnation.



GT FLOW PLUS



GT Flow Plus is Guardtech's mid-level Fan Filter Unit (FFU) – featuring an efficient AC motor which helps to deliver on low energy consumption, this FFU implements a gel seal.

GT Flow Plus is a robust, reliable Fan Filter Unit with an efficient AC motor and H14 HEPA filters.

Guardtech's mid-level FFU implements a Roomside Filter Change set-up as standard, as well as a gel seal.

Providing outstanding performance, efficiency and value in its class, GT Flow Plus is available with both individual and group control systems as well as a wide range of further options. Please ask a Guardtech rep for more information.

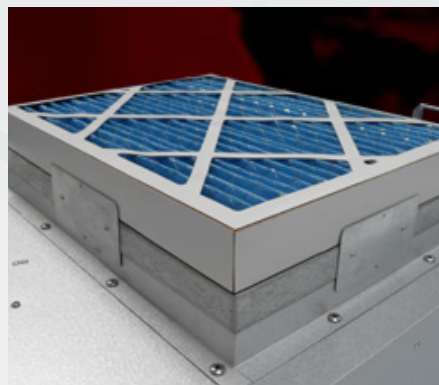
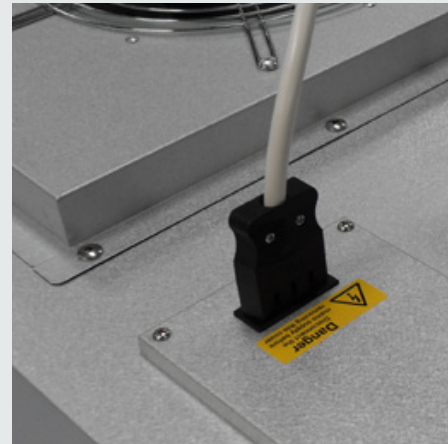

TECHNICAL FEATURES

EFFICIENT AC MOTORS

BACKWARD CURVED FAN

H14 HEPA FILTER

99.995% efficient at 0.3 micron particle size

TRIAC CONTROLLER OPTIONS

AIRFLO PLC CONTROLS

Options for intelligent FFU control and monitoring

GALVANISED CASING

LOW ENERGY CONSUMPTION

LOW OPERATING SOUND

TECHNICAL DRAWING

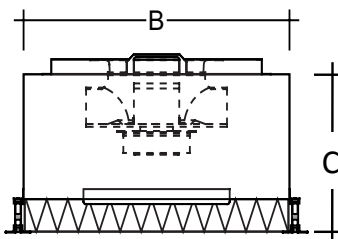
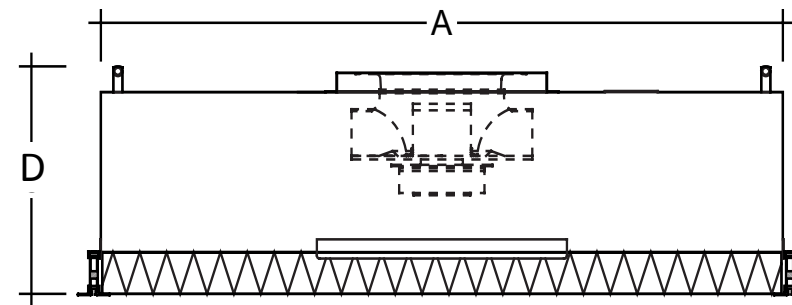

- The GT Flow Plus FFU allows for Roomside Filter Change.
- This FFU also features a gel seal.
- Topside Filter Change and gasket seal options also available.

DIMENSIONS

A	B	C	D
595	595	320	350
1195	595	320	350

OPTIONS

- ULPA filters – 99.9995% efficient at 0.12 micron particle size
- AMC (Airborne Molecular Contamination) filter options
- Air inlet spigot connection
- Plug and play wiring options
- G4 Pre-filter



BENEFITS

- Efficient AC motor
- Low energy consumption
- Both Roomside Filter Change and Topside Filter Change options available
- Either gel seal or gasket seal

COMPROMISES

- Comparatively lower price point
- Inferior noise reduction level performance compared to GT Flow Pro and Max
- Not as energy efficient as the EC motors
- No slimline model available (if required, speak to a member of the Guardtech team and an alternative will be provided)

APPLICATIONS



GT Flow Plus delivers a Fan Filter Unit that can cover a wide range of applications with a varying degree of air change rate requirements. However, this dependable all-rounder doesn't include the option for roomside change – which limits its appeal to controlled environment users in certain industries.





GT FLOW LITE



GT Flow Lite is Guardtech's entry-level filtration solution – it's the perfect solution for creating clean-rooms with vertical laminar flow. These are typically installed in false ceilings with proper aluminium profiles.

The GT Flow Lite frame is made of anodised extruded aluminium and is connected to a single-block aluminium plenum – which is both self-extinguishing and stamp-formed.

The filter box is fitted with a circular collar and the water-proof and fire-proof micro-fibre glass filter is mini-pleated with constant pitch using a polyurethane based sealant.

These filters are fitted thermo-plastic continuous separators and have white epoxy painted micro-drawn steel protection grids.

GT Flow Lite terminal filter boxes are tested and labelled with results. Both HEPA and ULPA class filters are available.



Hep-box replaceable HEPA terminal hood

TECHNICAL FEATURES

- Anodised Extruded Aluminium Frame
- **Self-extinguishing and Stamp-formed plenum**
- Mini-pleated, fire and waterproof micro-fibre glass construction
- **Thermo-plastic continuous separators**
- Epoxy painted micro-drawn steel protection grids
- **All products are tested and labelled with test results**

Technical Feature	HEP14 - Terminal Filter Box	U15 - Terminal Filter Box
Efficiency MPPS	99.995%	99.9995%
EN 1822:2009 Classification	H14	U15
Suggested Final Pressure Drop	400 Pa	400 Pa
Maximum Pressure Drop	600 Pa	600 Pa
Maximum Operating Temperature	60°C	60°C
Maximum Relative Humidity	90%	90%

PRODUCT SPECIFICATION & PERFORMANCE

Product Code	Dimensions (mm)			Collar ø (mm)	Nominal Air-Flow Rate Q		Filtering Surface m ²	Initial Pressure Drop Pa
	A	B	C		m ³ /h	m ³ /s x 10 ⁻³ **		
GALIFB226060-H14**	595	595	220	250	570	159	9.5	130
GALIFB226060-U15***	595	595	220	250	570	159	9.5	150
GALIFB221260-H14***	1195	595	220	315	1146	321	19.1	130
GALIFB221260-U15***	1195	595	220	315	1146	321	19.1	150

*1 m³/s x 10-3 = 1 l/s / ** = Polystyrene plenum box / *** = Aluminum plenum box

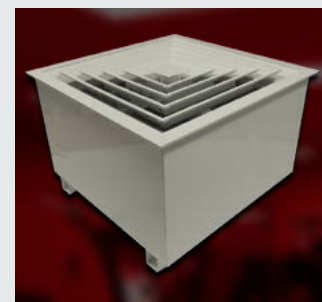

Gel seal terminal hood

TECHNICAL DRAWING

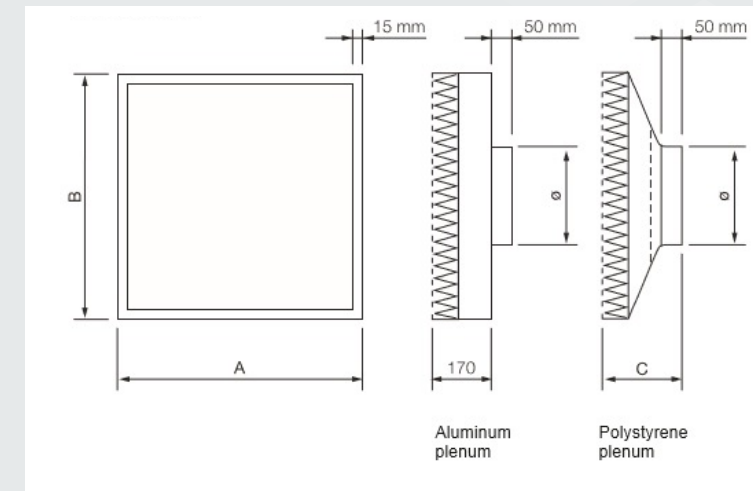

NOMINAL AIR FLOW v PRESSURE DROP

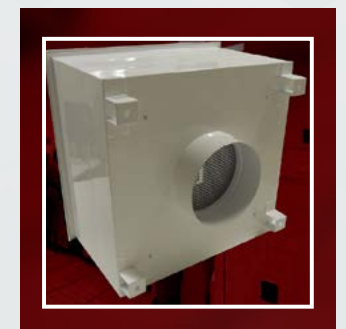
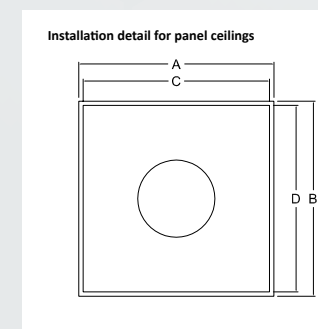
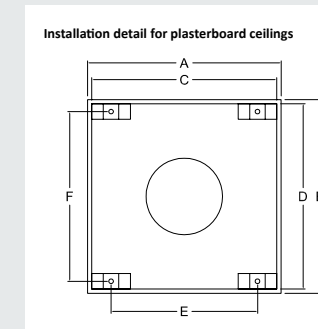
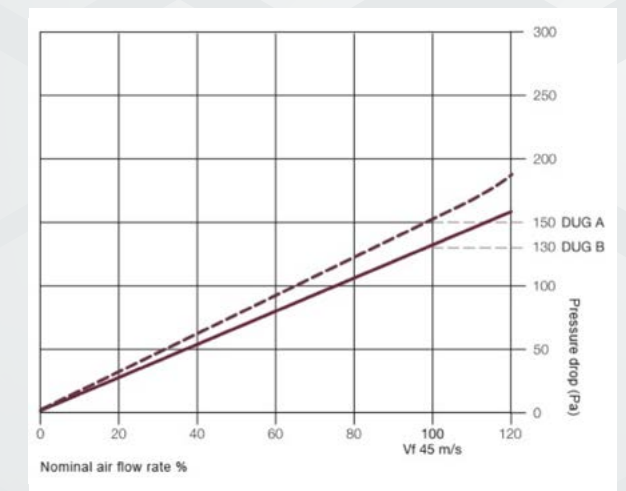

With a ridged, fully welded construction the gel seal terminal hood is manufactured from corrosion-resistant steel. With a depth of 80-125mm, for ease of installation and maintenance the filters offer roomside change.

BENEFITS

- Less maintenance required than more sophisticated FFU options
- Significantly more favourable price point
- Ease of installation
- Most superior option in terms of noise level reduction due to lack of motors in overhead plenum system

COMPROMISES

- Rudimentary fan speed control
- Not suitable for environments where more stringent control measures are required
- Less control generally
- Doesn't feature the same level of back-up peace of mind as multi-FFU system where fan failure can be supported by other units

APPLICATIONS



GT Flow Lite suits the least demanding of applications – most commonly laboratories or non-classified controlled environments where considerations on the movement of air and type of airflow is of far less significance.



QUICK-LOOK COMPARISON GUIDE

FEATURES



FEATURES	MAX	PRO	PLUS	LITE
EC Motor	<input checked="" type="checkbox"/>	<input checked="" type="checkbox"/>	<input type="checkbox"/>	<input type="checkbox"/>
AC Motor	<input type="checkbox"/>	<input type="checkbox"/>	<input checked="" type="checkbox"/>	<input type="checkbox"/>
Gel Seal	<input checked="" type="checkbox"/>	<input checked="" type="checkbox"/>	<input checked="" type="checkbox"/>	<input checked="" type="checkbox"/>
Gasket Seal option	<input type="checkbox"/>	<input type="checkbox"/>	<input checked="" type="checkbox"/>	<input type="checkbox"/>
Roomside Filter Change	<input checked="" type="checkbox"/>	<input checked="" type="checkbox"/>	<input checked="" type="checkbox"/>	<input checked="" type="checkbox"/>
Topside Filter Change option	<input checked="" type="checkbox"/>	<input checked="" type="checkbox"/>	<input checked="" type="checkbox"/>	<input checked="" type="checkbox"/>
H14 HEPA Filters (optional)	<input checked="" type="checkbox"/>	<input checked="" type="checkbox"/>	<input checked="" type="checkbox"/>	<input checked="" type="checkbox"/>
ULPA Filters (optional)	<input checked="" type="checkbox"/>	<input checked="" type="checkbox"/>	<input checked="" type="checkbox"/>	<input checked="" type="checkbox"/>
Low-energy consumption	<input checked="" type="checkbox"/>	<input checked="" type="checkbox"/>	<input checked="" type="checkbox"/>	<input checked="" type="checkbox"/>
Digital fan speed controller	<input checked="" type="checkbox"/>	<input checked="" type="checkbox"/>	<input checked="" type="checkbox"/>	<input type="checkbox"/>
Superior low operating sound	<input checked="" type="checkbox"/>	<input checked="" type="checkbox"/>	<input type="checkbox"/>	<input checked="" type="checkbox"/>





Guardtech

group

www.guardtech.com

Guardtech House,
Unit 1A Homefield Road,
Haverhill, Suffolk,
CB9 8QP